

## Latium Building Products

Billet Lane  
Normanby Enterprise Park  
Normanby Road  
Scunthorpe  
North Lincolnshire DN15 9YH  
Tel: 01724 400440 Fax: 1724 280241  
e-mail: info@latiumbp.com  
website: www.latiumbp.com



Agrément Certificate  
**11/4835**  
Product Sheet 2

## LATIUM BUILDING PRODUCTS ROOFLINE SYSTEMS

### BCE CELLULAR PVC-UE ROOFLINE SYSTEM

#### PRODUCT SCOPE AND SUMMARY OF CERTIFICATE

This certificate relates to the BCE Cellular PVC-UE Roofline System, comprising fascia, soffit and barge boards, soffit ventilator, and accessories for external use at the roofline as a substitute for timber or other conventional materials. The components of the system are available in two shades of white: mid-white and blue-white.

#### AGRÉMENT CERTIFICATION INCLUDES:

- factors relating to compliance with Building Regulations where applicable
- factors relating to additional non-regulatory information where applicable
- independently verified technical specification
- assessment criteria and technical investigations
- design considerations
- installation guidance
- regular surveillance of production
- formal three-yearly review.

#### KEY FACTORS ASSESSED

**Ventilation** — the ventilated soffit board can contribute towards providing the necessary roof space ventilation (see section 3).

**Strength and stability** — in terms of wind loading resistance the system can be used in all areas of the UK (see section 5).

**Performance in relation to fire** — the thicker cellular boards achieve a Class 1/ Class 1Y surface spread of flame for white PVC-UE profiles when tested in accordance with BS 476-7 : 1997 (see section 6).

**Durability** — the system will retain its decorative qualities for a period in excess of 35 years with only minor changes in surface appearance (see section 8).



The BBA has awarded this Agrément Certificate to the company named above for the system described herein. This system has been assessed by the BBA as being fit for its intended use provided it is installed, used and maintained as set out in this Certificate.

On behalf of the British Board of Agrément

A handwritten signature in black ink, appearing to read 'Simon Wroe'.

Simon Wroe  
Head of Approvals — Physics

A handwritten signature in black ink, appearing to read 'Greg Cooper'.

Greg Cooper  
Chief Executive

Date of First issue: 19 July 2011

*The BBA is a UKAS accredited certification body — Number 113. The schedule of the current scope of accreditation for product certification is available in pdf format via the UKAS link on the BBA website at [www.bbacerts.co.uk](http://www.bbacerts.co.uk)*

*Readers are advised to check the validity and latest issue number of this Agrément Certificate by either referring to the BBA website or contacting the BBA direct.*

British Board of Agrément  
Bucknalls Lane  
Garston, Watford  
Herts WD25 9BA

©2011

tel: 01923 665300  
fax: 01923 665301  
e-mail: [mail@bba.star.co.uk](mailto:mail@bba.star.co.uk)  
website: [www.bbacerts.co.uk](http://www.bbacerts.co.uk)

# Regulations

In the opinion of the BBA, the BCE Cellular PVC-U Roofline System, if used in accordance with the provisions of this Certificate, will meet or contribute to meeting the relevant requirements of the following Building Regulations:



## The Building Regulations 2010 (England and Wales)

Requirement:	C2(b)	Resistance to moisture
Comment:		The system will contribute to providing protection against the penetration of moisture to the inner surface of the building on which it is installed. See section 3.1 of this Certificate.
Requirement:	C2(c)	Resistance to moisture
Comment:		When used in accordance with this Certificate, the soffit ventilation products can contribute to enabling a roof to meet this Requirement. See sections 3.4 to 3.14 of this Certificate.
Requirement:	Regulation 7	Materials and workmanship
Comment:		The components of the system are acceptable. See section 8.1 and the <i>Installation</i> part of this Certificate.



## The Building (Scotland) Regulations 2004 (as amended)

Regulation:	8(1)(2)	Fitness and durability of materials and workmanship
Comment:		The system is acceptable. See sections 7.1, 7.2 and 8.1 and the <i>Installation</i> part of this Certificate.
Regulation:	9	Building standards – construction
Standard:	3.10	Precipitation
Comment:		The system will contribute to satisfying this Standard, with reference to clause 3.10.1 <sup>(1)(2)</sup> by giving protection against the penetration of moisture to the inner surface of the building on which it is installed. See section 3.1 of this Certificate.
Standard:	3.15	Condensation
Comment:		The soffit ventilation products can contribute to enabling a roof to meet this Standard, with reference to clauses 3.15.1 <sup>(1)</sup> , 3.15.3 <sup>(1)</sup> , 3.15.5 <sup>(1)</sup> and 3.15.7 <sup>(1)</sup> . See sections 3.4 to 3.14 of this Certificate. (1) Technical Handbook (Domestic). (2) Technical Handbook (Non-Domestic).



## The Building Regulations (Northern Ireland) 2000 (as amended)

Regulation:	B2	Fitness of materials and workmanship
Comment:		The system is acceptable. See section 8.1 and the <i>Installation</i> part of this Certificate.
Regulation:	B3(2)	Suitability of certain materials
Comment:		The system is acceptable. See sections 7.1 and 7.2 of this Certificate.
Regulation:	C4(b)	Resistance to ground moisture and weather
Comment:		The system will contribute to providing protection against the penetration of moisture to the inner surface of the building on which it is installed. See section 3.1 of this Certificate.
Regulation:	C5	Condensation
Comment:		The soffit ventilators can contribute towards enabling a roof to meet the requirements of this Regulation. See sections 3.4 to 3.14 of this Certificate.

## Construction (Design and Management) Regulations 2007

## Construction (Design and Management) Regulations (Northern Ireland) 2007

Information in this Certificate may assist the client, CDM co-ordinator, designer and contractors to address their obligations under these Regulations.

See section: 9 *General* (9.7 to 9.10) of this Certificate.

# Non-regulatory Information

## NHBC Standards 2011

NHBC accepts the use of the BCE Cellular PVC-UE Roofline System, when installed and used in accordance with this Certificate, in relation to *NHBC Standards*, Chapter 7.2 *Pitched roofs*.

# General

This Certificate replaces Certificate 96/3234, Second issue, which was originally issued on 15 March 1996.

## 1 Description

1.1 The BCE Cellular PVC-UE Roofline System is for external use on roofs as a substitute for timber or other conventional materials.

1.2 The system comprises a range of PVC-UE (cellular PVC-U) boards including fascia/barge boards (see Figure 1), plain and vented soffits (see Figure 2) together with ancillary components including extruded trims, and injection moulded joints (see Figure 3).

Figure 1 Fascia/Barge boards





Fascia board	Overall thickness (mm)	Width (mm)	Fascia board	Overall thickness (mm)	Width (mm)
	10	100 - 454		9	150 - 405
ABE			ABF		
	18	150 - 405		16	150 - 405
ABL			ABB		
	18	150 - 405			
OBL					

Figure 2 Soffit Boards





Soffit board	Overall thickness (mm)	Width (mm)	Soffit board	Overall thickness (mm)	Width (mm)
 ABS	9	100 - 610	 ACV100	6	100
 ABV	9	100 - 610	 ACS150	6	150
 ABVV	9	150 - 450			

Figure 3 Selection of typical components and trims



1.3 The soffit ventilation products, which include a vented cellular boards and ventilator trims, provide a means of ventilating the roof void.

1.4 The system components are available in two shades of white: mid-white and blue-white.

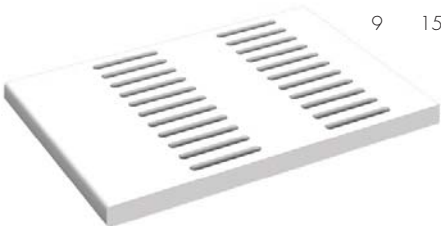
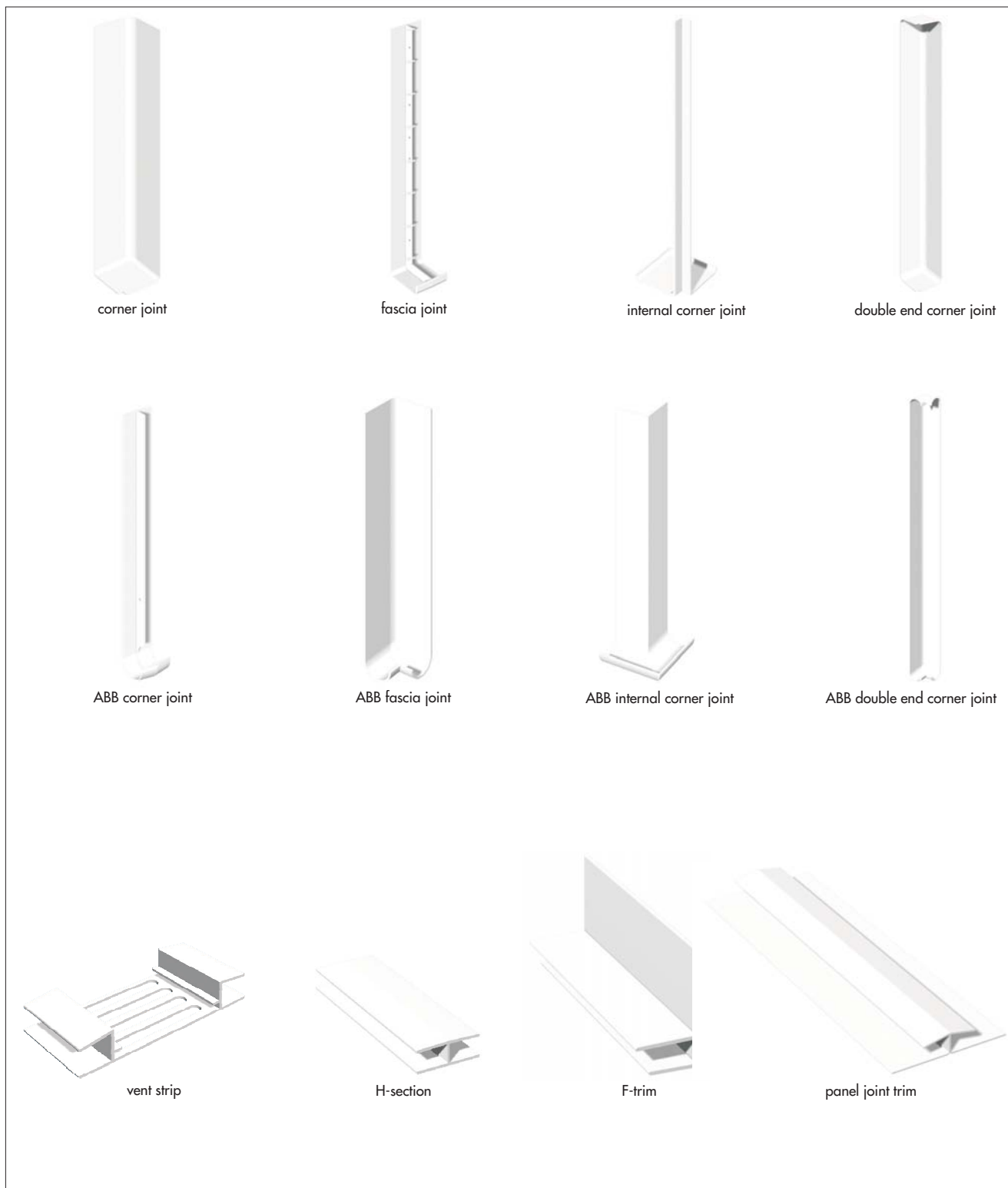
1.5 The PVC-UE boards comprise a closed cell cellular PVC-U core beneath an outer weathering impact modified PVC-U skin. The extruded trims are composed of impact modified PVC-U and the injection mouldings of PVC-U.

1.6 The fascia/barge boards are available in thicknesses of 10 mm, 16 mm and 18 mm, in a range of widths from 100 mm to 454 mm, in standard 5 m lengths of average density  $420 \text{ kg}\cdot\text{m}^{-3}$  and with a nominal skin thickness of 0.5 mm.

1.7 The PVC-UE boards are manufactured by co-extruding a high impact calcium/zinc PVC-U compound onto a foamed calcium/zinc PVC-U compound, cooling and forming to section. Cellular PVC-U is formed during the process by the evolution of gas from blowing agents present in the PVC-U compound. A transparent polythene film, colour coded to denote the shade of white, is applied to the outer face of the extrusion before the board is cut to length.

1.8 The PVC-U trims are manufactured using conventional extrusion and injection moulding techniques.

1.9 Continuous quality control is undertaken during manufacture. Checks include:

- appearance
- colour
- dimensions
- weight per metre
- impact strength.

1.10 The recommended fixings for use with various components of this system are listed in Table 1.

Table 1 System components and their recommended fixings

Component thickness	Type of fixing
9 mm fascia/barge board	Plastic headed 40 mm x 4 mm austenitic stainless steel screws <sup>(1)</sup> or 50 mm x 3 mm austenitic annular ring shank stainless steel nails
16 mm, 18 mm fascia/barge boards	Plastic headed 50 mm x 4 mm austenitic stainless steel screws <sup>(1)</sup> or 65 mm x 3 mm austenitic annular ring shank stainless steel nails
Soffit boards	Plastic headed 40 mm x 2.1 mm austenitic annular ring shank, stainless steel pins
Cladding soffits	30 mm x 2.1 mm austenitic annular ring shank stainless steel pins
Gutter brackets <sup>(2)</sup>	25 mm x 4.8 mm parallel thread austenitic stainless steel screws

(1) Grade A4 to BS EN ISO 3506-1 : 2009.

(2) For fixing to 16 mm, 18 mm fascia board.

1.11 A low modulus neutral cure silicone sealant is used for fixing joints.

## 2 Delivery and site handling

2.1 The fascia/barge board, soffit and trim profiles are delivered to site in packs sealed in polythene sleeves and identified with BCE product marking and the BBA identification mark incorporating the number of this Certificate. Pack quantities vary depending on the type of profile.

2.2 Packs should be stored on a clean, level surface in stacks not exceeding 1 m in height and restrained from collapse. If stored externally, the packs should be kept under cover.

## Assessment and Technical Investigations

The following is a summary of the assessment and technical investigations carried out on the BCE Cellular PVC-UE Roofline System.

## Design Considerations

### 3 General



3.1 The BCE PVC-UE Roofline System is suitable for external use to provide a protective and decorative trim to roofs where timber or other conventional materials would normally be used. The system will provide adequate protection to the interior of the building from the penetration of moisture.

3.2 The system must be fixed only to structurally sound building substrates, at centres not exceeding 600 mm. Rafter feet and gable ladders should be adequately supported to ensure rigidity. Replacement, rather than fixing over existing fascia, is recommended. Timber roof structures, to which the system is fixed, must be designed and/or constructed in accordance with the relevant Building Regulations and, as appropriate, in compliance with one of the following technical specifications:

- BS 5268-2 : 2002
- BS 5268-3 : 2006
- The Building Regulations 2010 (England and Wales), Approved Document A1/2, Section 2A
- The Building Regulations (Northern Ireland) 2000, Part D *Structure*.

3.3 Cellular PVC-UE components have a similar coefficient of thermal expansion to that of conventional solid PVC-U. A 5 mm gap should be provided at the end of each board, at the joint trim (ie 10 mm between boards), to allow for movement. Care should be taken not to install the system in extremes of temperature. The recommended temperature for installation is between 5°C and 25°C.

#### Ventilation



3.4 Soffit ventilators can contribute towards providing the necessary roof space ventilation. Guidance on the provision of adequate ventilation is given in the 2004 edition of the Approved Document C2 *Resistance to moisture* to the Building Regulations 2010 (England and Wales), and in BS 5250 : 2002, clause 8.4.

Guidance for Northern Ireland towards the provision of roof space ventilation is given in 'deemed to satisfy' Technical Booklet C : 1994 and BS 5250 : 2002.

3.5 When providing roof space ventilation it is essential that the airway must not become blocked by the loft insulation. This may be achieved by the use of a suitable BBA approved insulation retainer producing an air passage with an effective area (geometric free area) at least equal to that of the soffit ventilator used.

3.6 The soffit ventilator trims have effective areas of approximately 25 000 mm<sup>2</sup> per metre run (which is equivalent to a continuous slot of about 25 mm wide at eaves level) and they are suitable for the applications given in sections 3.8 to 3.10.

3.7 The vented soffit board ABV has an effective area of approximately 13 000 mm<sup>2</sup> per metre run (equivalent to a continuous slot 12.9 mm wide at eaves level) and is suitable for applications given in section 3.8. Vented soffit board ABW has an effective area of approximately 25 800 mm<sup>2</sup> per metre run (equivalent to a continuous slot of 25.8 mm wide at eaves level) and is suitable for applications given in sections 3.8 to 3.10.

3.8 For roofs with a pitch of 15° or more, where both the ceiling and insulation are horizontal, soffit ventilation products with a minimum effective area of 10 000 mm<sup>2</sup> per metre run, if used in accordance with section 3.5, can provide adequate ventilation to insulated loft spaces as set out in BS 5250 : 2002, clause 8.4. The soffit ventilation products should run along the eaves of the longest opposite sides of a rectangular roof to provide adequate cross-ventilation. The ventilators are suitable for use with traditional (semi-permeable) and high performance (impermeable) sarking felts. Consideration should be given to the use of high-level ventilation openings to increase the ventilation rate for roofs as recommended in BS 5250 : 2002, clause 8.4. The use of high-level ventilation openings is strongly recommended in roofs with a pitch greater than 35° or roof spans in excess of 10 m.

3.9 For roofs where the ceiling follows the pitch of the roof, soffit ventilation products with a minimum effective area of 25 000 mm<sup>2</sup> per metre run, if used in conjunction with suitable high-level ventilation, can provide adequately for roof voids as set out in BS 5250 : 2002, clause 8.4. It is essential that a minimum unrestricted air space of 50 mm is maintained between the underside of the roof deck and the top of the insulation. Consideration should be given to the probability of the sarking felt bowing between rafters and it should be ensured that this does not reduce the gap between felt and insulation to less than 50 mm. Where there is an obstruction to the ventilation, eg rooflights or a change in pitch of roof, adequate ventilation, in accordance with the requirements of BS 5250 : 2002, clause 8.4, should be provided above and below the obstruction using suitable ventilators. The required ventilation at high level and around obstructions may be achieved by using a suitable BBA approved ventilator.

3.10 For roofs with a pitch of less than 15°, soffit ventilation products with a minimum effective area of 25 000 mm<sup>2</sup> per metre run, if used in accordance with section 3.5, can provide adequate ventilation to insulated roof voids as set out in BS 5250 : 2002, clause 8.4. When providing roof space ventilation for flat roofs, it is essential that a minimum unrestricted air space of 50 mm is maintained between the underside of the roof deck and the top of the insulation. Ventilation should be provided along two opposite sides of the deck: where possible these should be the two longest sides in order to achieve maximum cross-ventilation. The recommendations contained in BS 5250 : 2002, clause 8.4, should be followed when planning the provision of ventilation to flat roofs, especially where spans exceed 5 m, or for concrete deck roofs. Where a flat roof has a span of greater than 10 metres, or is not of a simple rectangular plan, more ventilation will be required, totalling at least 0.6% of the total area of the roof. It should be noted that cold flat roof construction is generally unacceptable in Scotland and not the preferred option elsewhere in the UK<sup>(1)</sup>.

(1) See BRE Report (BR 262 : 2002) *Thermal insulation: avoiding risks*.

3.11 Where soffit ventilation products are used in lean-to or mono-pitched roofs, high-level ventilation, in accordance with BS 5250 : 2002, clause 8.4, must be provided.

3.12 Where a pitched roof abuts a wall, additional high-level ventilation must be arranged to provide an open area at least equal to a 5 mm slot running the full length of the abutment.

3.13 Soffit ventilation products sections meet NHBC requirements for protection against the ingress of birds, rodents or large insects. For applications covered by section 3.8, a mesh may be incorporated into the ventilator trim to increase this protection.

3.14 The dimensions of the slots in soffit ventilation products are such that the risk of blockage is limited. However, blockage by insects and debris will impair their performance as vents and they should be examined occasionally and cleared if necessary.

## 4 Practicability of installation

The system is designed to be installed by a competent general builder, or a contractor, experienced with this type of system.

## 5 Strength and stability

5.1 When installed in accordance with this Certificate, the system will withstand, without damage or permanent deflection, the wind loads likely to be encountered in the United Kingdom. In exposed locations care should be taken to ensure that all profiles are adequately fixed.

5.2 The system has adequate resistance to hard and soft body impacts likely to occur in practice.

5.3 PVC-U gutters, as specified in BS 4576 -1 : 1989, may be screw-fixed directly to the 16 mm, and 18 mm boards. Gutter bracket spacings must not exceed 1 m; reduced spacings are recommended in the Scottish Highlands where snow loading is more of a consideration. Other lightweight gutters may also be screw-fixed provided the maximum bracket loading, covered in BS 4576-1 : 1989 is not exceeded.

5.4 The 16 mm and 18 mm boards will support all eaves tiles in common usage in the UK (up to 10 kg load per 1 m length of fascia) provided that the boards are installed within the requirements of this Certificate.

5.5 Apart from the exception detailed in section 5.4, the fascia boards are not loadbearing and must not be used to support fixtures such as roof tiles, gutters, other components of the roof structure or television aerials. Telephone wires and power cables may be run along the boards but the main brackets for these services should be fixed through the fascia to structurally sound timber.

## 6 Performance in relation to fire

6.1 When tested in accordance with BS 476-7 : 1997 the 16 mm and 18 mm boards achieved a Class 1 surface spread of flame rating, and the 10 mm board a Class 1Y rating.

6.2 On exposure to fire, PVC-U tends to char and may fall away. The spread of flame along its surface is limited. It is unlikely that the roof trim system will significantly affect the overall fire performance of any roof in which it is installed.

6.3 Where it is normal practice to carry the eaves box over between dwellings, it is important that the box is fire-stopped at compartment walls.

## 7 Maintenance



7.1 The system can be cleaned by washing with water and mild detergent. Abrasive or solvent-based cleaners should not be used. Materials can be cut and drilled, using normal woodworking tools, if repairs are required.

7.2 As with all PVC products, paint can adversely affect the impact strength of the PVC-U sections, and the application of dark colours could lead to a risk of thermal distortion. Painting is therefore not recommended.

## 8 Durability



8.1 Results of accelerated weathering tests indicate that BCE Cellular PVC-UE is as durable as conventional solid PVC-U.

8.2 The system will retain its decorative qualities for a period in excess of 35 years with only minor changes in surface appearance. It will also retain adequate impact resistance.

8.3 Where the timber substrate is preservative treated with copper/chrome/arsenic<sup>(1)</sup> or copper/chrome/boron, care must be taken to ensure that sufficient time is allowed for complete fixation of the preservative (approximately seven days) to avoid corrosion of screws and nails used to fix the components.

(1) CCA products should not be used in domestic applications according to European Union Restrictions

# Installation

## 9 General

9.1 Installation of the BCE Cellular PVC-UE Roofline System must be carried out in accordance with the manufacturer's instructions and the requirements of this Certificate (see Figure 4).

9.2 Fascia, soffit and barge boards should be fixed to preservative-treated, structurally sound timber at centres not exceeding 600 mm, using the screws and nails specified by the manufacturer.

9.3 The 16 mm and 18 mm fascia boards may be used to support PVC-U and other lightweight gutters (see section 5.3). Other components of the system are not loadbearing (see section 5.5).

9.4 The 16 mm and 18 mm boards may be used to support eaves tiles (see section 5.4). In certain geographical/topographical locations the eaves tiles will need to be restrained in order to resist wind uplift. Guidance on this fixing should be sought from the manufacturer of the eaves tiles.

9.5 Sarking felt should be checked to ensure that it is in good condition and extends onto the verge rafter and over a felt support into the gutter at the eaves. Damaged or worn felt should be replaced or if occurring at the eaves, made watertight using an eaves protector.

9.6 Soffit ventilation products should be selected and installed so that the roof ventilation conforms to the relevant national Building Regulations.

9.7 Normal precautions should be taken when working at roof level. The use of protective goggles when cutting and nailing is recommended.

9.8 The components of the system are easy to work using normal woodworking tools for cutting, drilling and shaping. Handsaws should have a fine-toothed blade. Hand-held and bench-mounted power tools with a carbide-tipped blade should be run at speeds similar to, or higher than, those normally used for timber.

9.9 When using power tools to cut or shape the product, it is advisable to use a coarse particle dust mask and eye protection.

9.10 No special training is required to install the roof trim system correctly, provided the manufacturer's instructions and the procedures outlined in section 9 of this Certificate are followed.



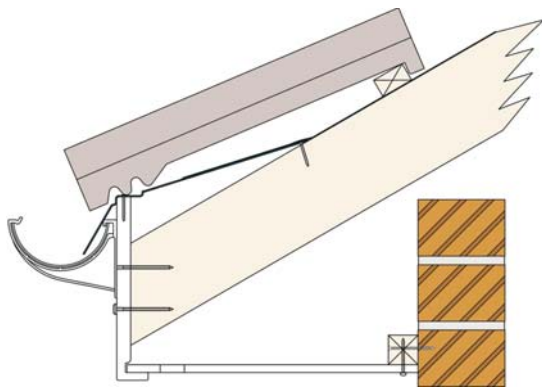

ABL fascia and 9 mm vented soffit

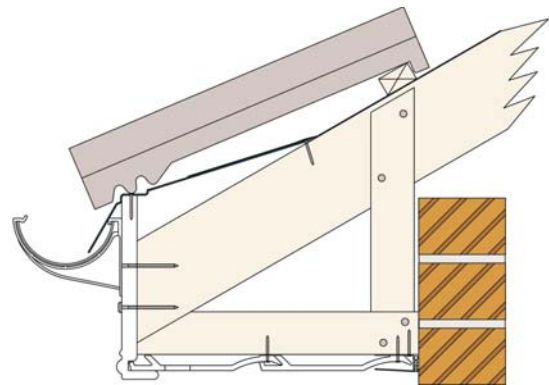

OBL fascia and 150 mm shiplap cladding



ABB fascia and 9 mm vented soffit



additional support

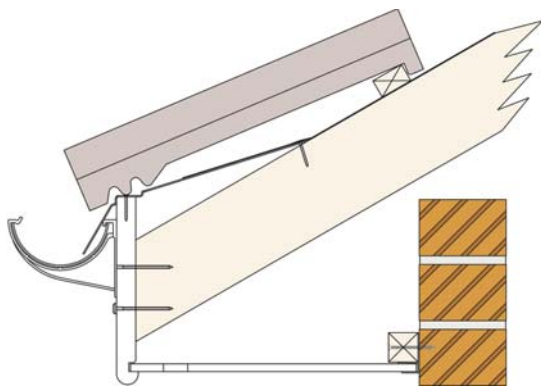
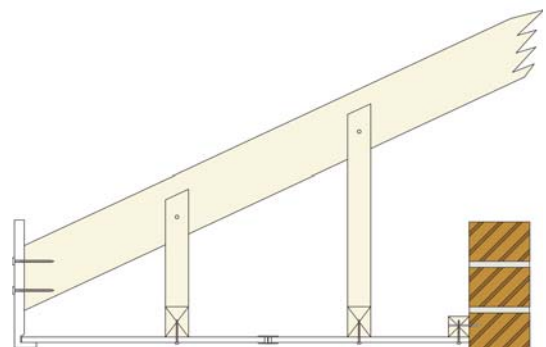
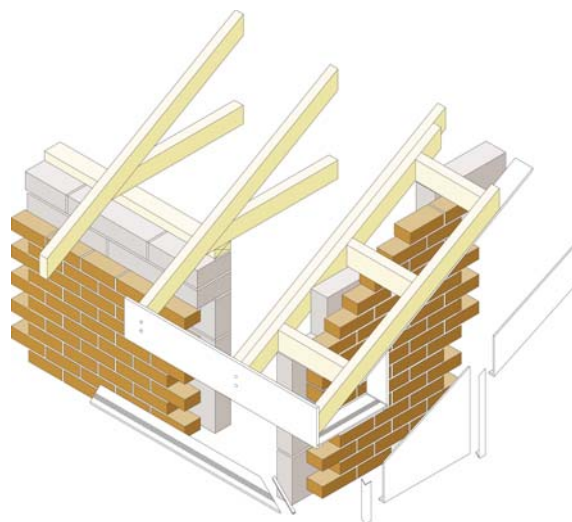

box end construction

## 10 Procedure

10.1 Selected boards and accessories are assembled and cut to size.

10.2 Rafter feet are cut to a line.

10.3 Noggings, soffit bearers, battens, eaves fillets, brackets and other additional timber supports are fixed to a sound substrate.

10.4 Protective films should be removed just prior to fixing.

10.5 The summary for the installation details of fascia, soffit and barge boards (see sections 10.6 to 10.17) should be read with reference to the appropriate diagrams shown in Figures 4 and 5.

### Fascia boards

10.6 Fascia boards are fixed to rafter feet at centres not exceeding 600 mm using at least two fixings per rafter. For the 10 mm board, 40 mm screws or 50 mm annular ring shank nails may be used; for the 16 mm and 18 mm boards either 50 mm screws or 65 mm annular ring shank nails may be used. For increased rigidity 10 mm fascia boards must be fixed over timber backing boards using 40 mm screws or 50 mm annular ring shank nails.

10.7 Where necessary, fascia boards are joined using an appropriate cover joint trim. Depending on the board, the joint<sup>(1)</sup> may be:

- a nailed joint, in which the trim is fixed to the end of one board by inserting a specified 30 mm nail through the hole provided in the spine of the trim or
- an adhesive joint, in which the trim is fixed over the joint and to the end of one board with a low modulus neutral cure silicone, after both boards are in place.

(1) In each case an expansion gap is provided between boards, equivalent to 10 mm between two boards.

10.8 An appropriate corner trim, cut to size, is used at external corners<sup>(1)</sup>. This is an adhesive joint, in which the trim is fixed over the joint and to the end of one board with a low modulus neutral cure silicone, after both boards are in place.

(1) An expansion gap is left at the end of each board, equivalent to 5 mm per board.

10.9 Internal corner joints are covered by internal corner trims. These are fixed to the end of one board with a low modulus neutral cure silicone as described for the adhesive external corner joint in section 10.8.

10.10 For the 16 mm and 18 mm boards, gutter brackets may be fixed directly into the board using, for each bracket, at least two 25 mm long by 4.8 mm diameter parallel thread form screws recommended by the manufacturer, ensuring that the screws penetrate the rear face of the board and that the bracket spacings do not exceed 1 m. For the 10 mm board, gutter brackets are screwed through the fascia board into the timber support.

### Soffit boards

10.11 Soffit boards fitted into or butted up against fascia boards may be used in a variety of ways as illustrated in Figure 4. Horizontal soffits may be fixed to battens secured to the wall, fixed to soffit bearers, or fitted into soffit channels fixed to the wall. Sloping soffits are fixed directly to the underside of rafters.

10.12 Soffit boards up to 300 mm wide may be fitted between the fascia and soffit channel without additional fixing. Otherwise soffit boards should be fixed at maximum 600 mm centres along their length and 300 mm centres across their width, using the specified 40 mm annular ring shank pins, with 30 mm cladding pins used for the soffit cladding.

10.13 Ventilated soffit boards may be used to provide the required ventilation to roof voids. Alternatively, soffit ventilator trims may be incorporated between soffit and fascia boards.

10.14 An H-section trim (soffit joint trim) is used to join soffit boards.

### Barge boards

10.15 Barge boards are installed by fixing fascia boards to a gable ladder, rafter face or noggings, using the procedures given in section 10.6.

10.16 Barge boards meeting at a ridge should be mitred to the appropriate angle, allowing 5 mm for expansion between the ends of each board. To conceal the joint a cover joint trim is fixed to the end of one board using a low modulus neutral cure silicone. Further low modulus neutral cure silicone sealant may be applied between the ends of the boards as an additional fixing.

10.17 Box ends are constructed from fascia board and trims to suit the roof pitch and overhead requirement. Any timber framework required in the construction of the box end must be preservative treated.

Figure 5 Typical joint details

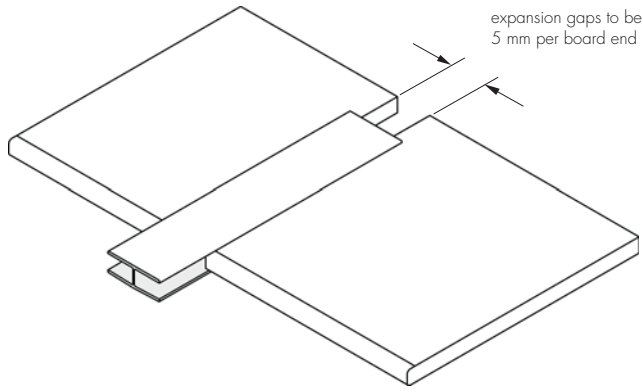

soffit joint installation

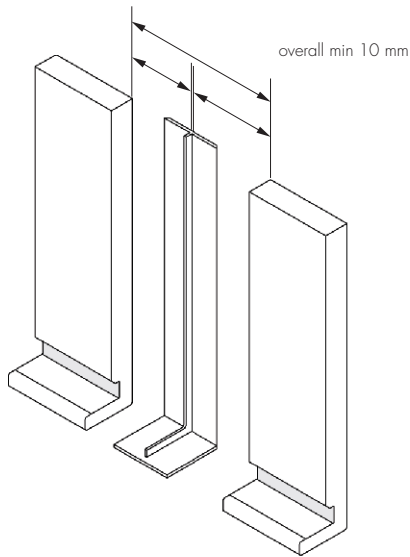

fascia joint installation

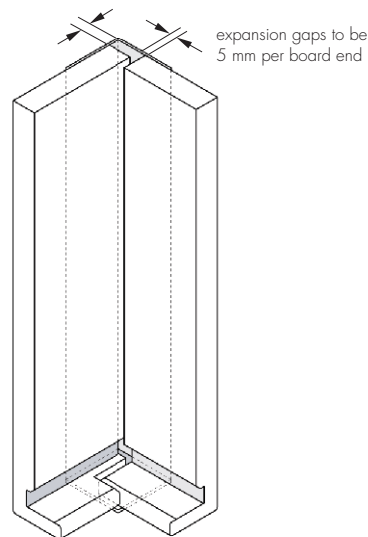

corner joint installation

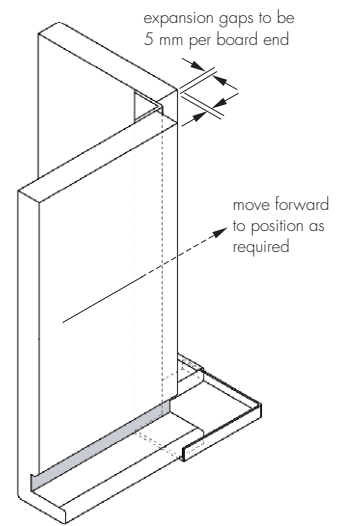

internal joint installation

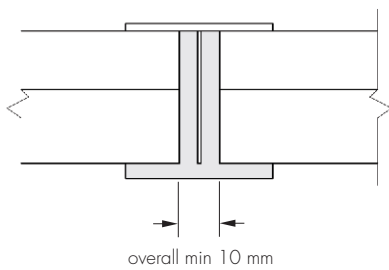

butt joint plan view

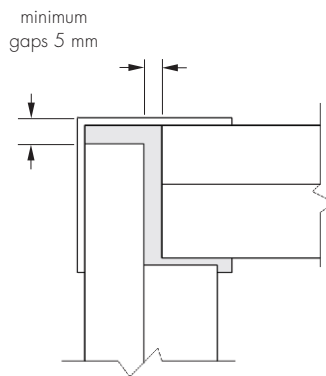

corner joint plan view

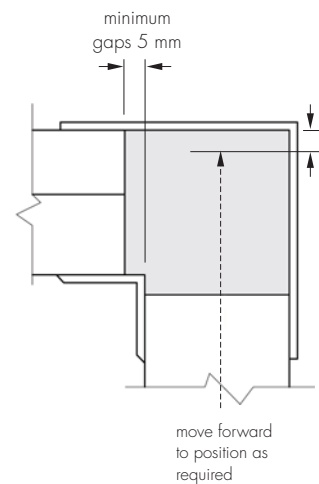

internal corner plan view

## 11 Tests

Results of tests conducted on the BCE cellular PVC-UE Roofline system were assessed to determine:

- thickness of layers
- density
- weight per linear metre
- ash content
- tensile strength and elongation
- flexural strength and modulus of elasticity
- dimensional stability
- impact strength, DHC (dehydrochlorination) and appearance after UV ageing
- impact strength, DHC (dehydrochlorination) and appearance after heat ageing
- impact strength and appearance after watersoak ageing
- nail pull-through
- gutter fixing
- heat reversion
- acetone resistance
- stress relief
- tile and gutter loading.

## 12 Investigations

12.1 The dimensions of cellular boards and trims were checked.

12.2 An assessment was made of existing test data relating to:

- surface spread of flame
- colour stability.

12.3 The manufacturing process, including the methods adopted for quality control, were examined and details were obtained of the quality and composition of the materials used.

12.4 The practicability of installation was assessed.

12.5 Calculations were undertaken and an assessment was made of the product's resistance to wind loading. Visits to sites were made to inspect installations in-progress, in order to assess the practicability of installation. An assessment was made of the acceptability of soffit ventilators in meeting ventilation requirements.

## Bibliography

- BS 476-7 : 1997 *Fire tests on building materials and structures — Method of test to determine the classification of the surface spread of flame of products*
- BS 4576-1 : 1989 *Specification for unplasticized polyvinyl chloride (PVC-U) rainwater goods and accessories — Half-round gutters and pipes of circular cross-section*
- BS 5250 : 2002 *Code of practice for control of condensation in buildings*
- BS 5268-2 : 2002 *Structural use of timber — Code of practice for permissible stress design, materials and workmanship*
- BS 5268-3 : 2006 *Structural use of timber — Code of practice for trussed rafter roofs*
- BS EN ISO 3506-1 : 2009 *Mechanical properties of corrosion-resistant stainless steel fasteners — Bolts, screws and studs*

## 13 Conditions

13.1 This Certificate:

- relates only to the product/system that is named and described on the front page
- is issued only to the company, firm, organisation or person named on the front page — no other company, firm, organisation or person may hold or claim that this Certificate has been issued to them
- is valid only within the UK
- has to be read, considered and used as a whole document — it may be misleading and will be incomplete to be selective
- is copyright of the BBA
- is subject to English Law.

13.2 Publications, documents, specifications, legislation, regulations, standards and the like referenced in this Certificate are those that were current and/or deemed relevant by the BBA at the date of issue or reissue of this Certificate.

13.3 This Certificate will remain valid for an unlimited period provided that the product/system and its manufacture and/or fabrication, including all related and relevant parts and processes thereof:

- are maintained at or above the levels which have been assessed and found to be satisfactory by the BBA
- continue to be checked as and when deemed appropriate by the BBA under arrangements that it will determine
- are reviewed by the BBA as and when it considers appropriate.

13.4 The BBA has used due skill, care and diligence in preparing this Certificate, but no warranty is provided.

13.5 In issuing this Certificate, the BBA is not responsible and is excluded from any liability to any company, firm, organisation or person, for any matters arising directly or indirectly from:

- the presence or absence of any patent, intellectual property or similar rights subsisting in the product/system or any other product/system
- the right of the Certificate holder to manufacture, supply, install, maintain or market the product/system
- individual installations of the product/system, including their nature, design, methods, performance, workmanship and maintenance
- any works and constructions in which the product/system is installed, including their nature, design, methods, performance, workmanship and maintenance
- any loss or damage, including personal injury, howsoever caused by the product/system, including its manufacture, supply, installation, use, maintenance and removal.

13.6 Any information relating to the manufacture, supply, installation, use, maintenance and removal of this product/system which is contained or referred to in this Certificate is the minimum required to be met when the product/system is manufactured, supplied, installed, used, maintained and removed. It does not purport in any way to restate the requirements of the Health and Safety at Work etc. Act 1974, or of any other statutory, common law or other duty which may exist at the date of issue or reissue of this Certificate; nor is conformity with such information to be taken as satisfying the requirements of the 1974 Act or of any statutory, common law or other duty of care.